

# MYLOCOSOUND

## UNIVERSAL PREMIUM SOUND FOR LARGE SCALE ELECTRIC TRAMS & STREETCARS

### 1. OVERVIEW

- Easy installation using screw terminals with no soldering.
- Uses a TV remote control to adjust the sounds to match the prototype vehicle.
- Provides two selectable motor sounds which adjust to match the vehicle speed and load.
- Three bells/gongs.
- Eight horns/whistles, five with adjustable pitch to suit the vehicle.
- Full remote control of sounds.
- Optional brake and rail squeal.
- For track powered DC or battery powered radio controlled railways.
- Measures 55mm x 33mm x 11mm.

### 2. CONTENTS

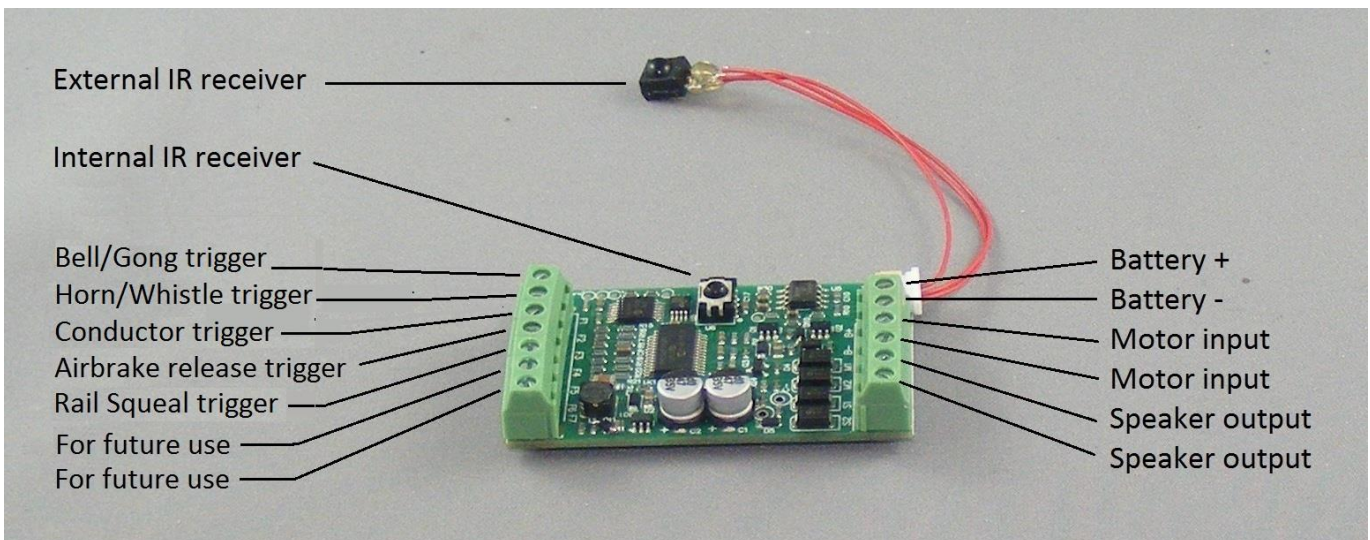

The soundcard generates recorded and synthesised sound which is adjustable to reproduce the sounds of most steam locos and railmotors. The terminal connections on the right are necessary for the soundcard to generate a chuff which varies with the loco speed and load. The terminal connections on the left trigger the various sounds where the locomotive controller has the appropriate outputs available. The trigger terminals are labelled F1 to F7 and are referred to by these labels in these instructions e.g. "Triggering F1" means to close a contact between the F1 terminal and the Battery negative terminal.

Sounds can also be triggered by the infra-red TV remote control which works with the soundcard. Although it can be used when running in the garden, the remote control is intended mainly for the adjustment and testing of sounds due to its short range.

The remote control communicates with the soundcard via two infra-red receivers. One is located on the soundcard and the other is on a flying lead which allows it to be fixed to any external surface of the loco. Adjustments to the sounds can then be made without taking the loco apart to access the soundcard.

### 3. SPEAKERS AND SOUND QUALITY

The soundcard requires an 8 ohm loudspeaker which is not included. A 4 ohm speaker can also be used but you may cause the soundcard to overheat and temporarily shut down if the volume is very high and the soundcard is in a confined space. Your choice of speaker is highly important because it determines the quality of the sound produced.



1. To get maximum volume, the rated (or RMS) power should be 3 watts. A 1 watt or lower speaker will fall short on volume. Speakers exceeding 3 watts can be used but will not produce any more volume due to the limited output of the soundcard amplifier.
2. The resonant frequency should ideally be below 350 Hz but certainly below 500 Hz. The lower the resonant frequency, the deeper the steam chuff, whistle, etc.
3. Use the largest diameter which you can fit in your loco. 50mm is the most popular.

The lowest cost option is to fit speaker from your local consumer electronics store. Typically these come in 27mm or 57mm diameters. Use the largest which you can fit in your loco.



For a better quality sound and more volume, the speaker needs to be baffled. That means that it needs to be built into the front face of an airtight box so that sound is heard only from the front of the speaker and none from the back. The plastic top of a spray paint can is good for making a baffle as shown in the diagram.

A good solution, which ensures high quality sound with lots of deep throbbing bass, is to purchase an 8 ohm impedance external speaker unit for iPod and MP3 music players and remove the two speaker modules, in their enclosures, for use in two locos. These are readily available at consumer electronics stores.



Speakers can be connected to the terminals either way around.

It is also possible to boost the volume by using a commercial stereo amplifier. Section 13 of these instructions shows how this can be done. Use of an external amplifier is recommended for ride on railways.

### Important Notes

The soundcard is designed for outdoor use and may not work correctly under bright incandescent lights on a workbench. LED lights are okay.

The soundcard is in a "sleep" mode when not in use. Connecting it to power at the B+ and B- terminals will not wake it up. It must also be connected to a motor at the M1 and M2 terminals as well. The small voltage it sees at the motor will wake it up and it will then stay awake for as long as it has power.

#### 4. INSTALLING THE SOUND CARD IN A TRACK POWERED LOCOMOTIVE, DC OR DCC

The soundcard is suitable for use on analogue DC track powered railways on which the following wiring diagram should be used:

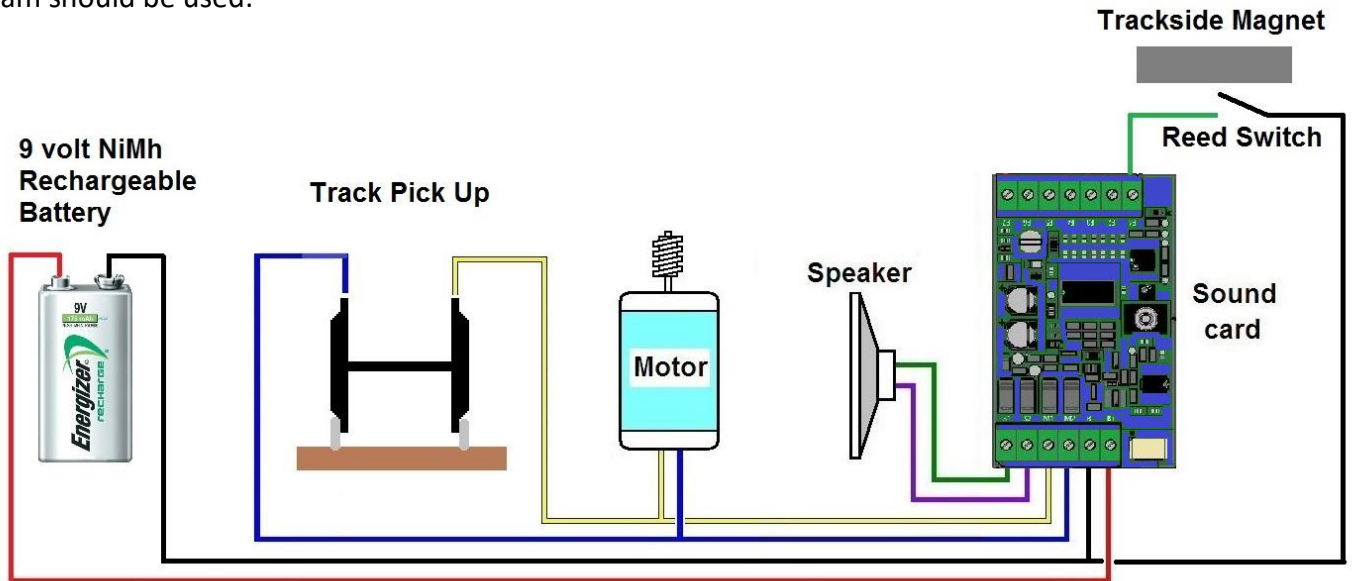

The wiring diagram below shows the connections for the DC jumper board in a Bachmann locomotive.

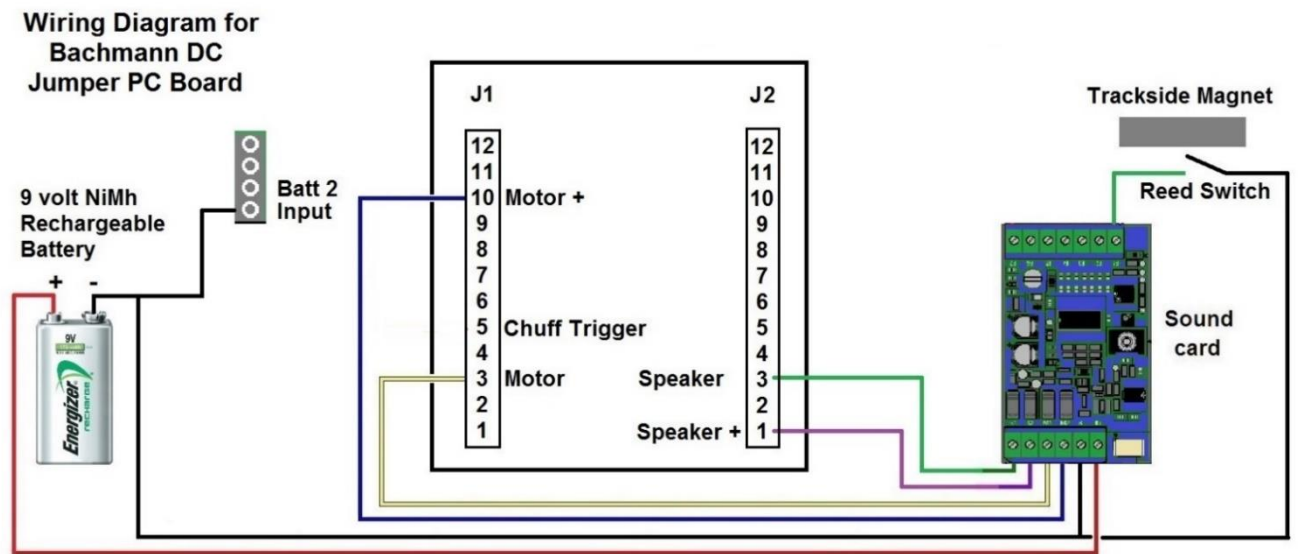

When the motor voltage is below seven volts it is insufficient to power the soundcard. Therefore a 9v volt PP3 or a 7.2v cordless phone battery is used to drive the soundcard and produce sound when the loco is static or moving slowly. This battery will be automatically recharged whenever the motor voltage is at about 1.8 volts higher than the battery voltage so there should never be a need to remove the battery for recharging. However, the battery must be a Nickel Metal Hydride type; Lithium and Nickel Cadmium batteries must not be used. On small shunting layouts, the loco speed is often not high enough for charging to take place. Some owners of shunting layouts put an isolation switch on the loco motor circuit so that they can turn up the power to recharge the battery without having the loco moving.

On analogue DC layouts which have pure DC controllers (as opposed to PWM controllers) you may need to give the throttle a bit of a tweak to start the sound. On those layouts, the sound will automatically turn off after one minute of inactivity and another tweak will turn it back on. With the more common PWM controllers and with DCC the sound will turn on automatically and stay on.

When the loco is removed from the track the soundcard will go into a “sleep” mode to preserve the battery charge. A fully charged battery should retain charge for over a year.

Because most DC controllers do not have function buttons, an alternative way of triggering the horn, bell and other sounds needs to be found. The options are:

1. You can set the whistle to sound automatically three times a minute when the train is running. Other sounds can also be triggered automatically. This is described in section 8.
2. You can connect the soundcard whistle trigger to a reed switch which you mount on the bottom of the loco. Then install magnets in the track where you want the horn to sound eg. at the approaches to a level crossing. The horn will then sound briefly as the loco crosses each magnet.
3. Use the remote control, supplied with the soundcard, to trigger all the sounds as described in section 8. However, infra-red remote controls are not designed for long distance use outside. On an overcast but bright day, the remote control, powered by AA or AAA batteries will probably operate up to three metres away.

Any combination, or all, of these methods can be used.

With DCC, the soundcard is not a decoder and cannot trigger sounds directly from the controller. Therefore the above methods are used to trigger the sounds. Some decoders have a servo output which can be used to trigger sounds from the controller buttons by using a servo switch. They may also have a constant DC power output which can replace the battery if it is in the voltage range 8 to 24 volts. These connection options are shown below:

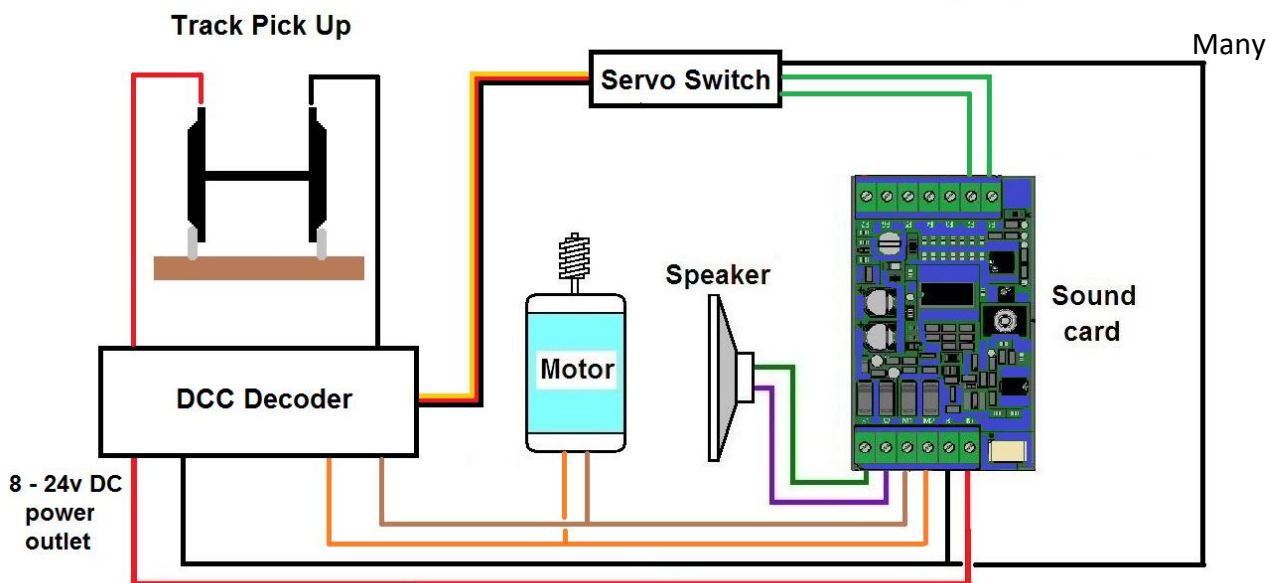

decoders also have function outputs which can be used to trigger sounds. However, this is technically difficult and you should only attempt it if you are very familiar with your decoder and the setting of CVs.

Now continue reading at section 6.

## 5. INSTALLING THE SOUND CARD IN A BATTERY POWERED LOCOMOTIVE OR RAILCAR

The wiring diagram below shows a typical installation for common types of battery powered radio control systems.

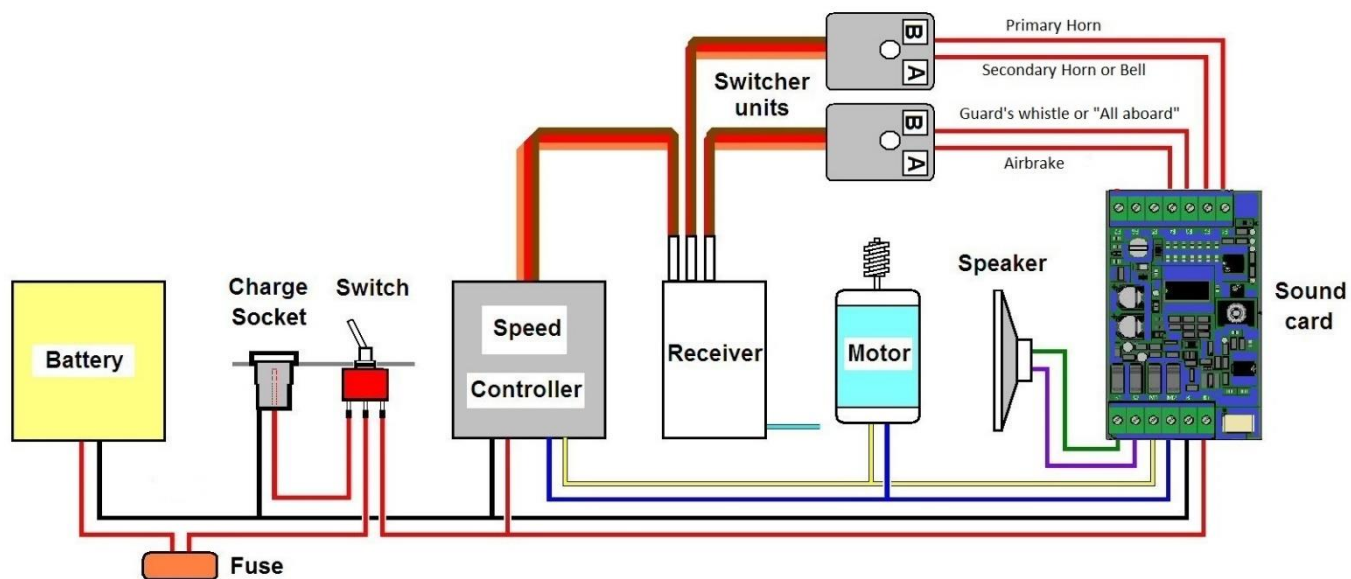

The receiver shown has two function channels, each of which can operate two triggers via two switcher units. The fifth soundcard trigger, the turbocharger, therefore cannot be radio controlled and will need to be switched on, if required, by the IR remote control. A suitable switcher unit is the Pololu 2802.

The above wiring diagrams can be seen in colour by visiting the web site at [www.mylocosound.com](http://www.mylocosound.com) and select the 'How to Install' menu. Also shown are specific wiring diagrams for Deltang, Fosworks, RCS, Railboss, Revolution, Localinc, BlueRail, LocoRemote, Piko and others.

## 6. THE INFRA-RED RECEIVERS

The infra-red receivers accept commands from the handheld remote control to adjust or trigger sounds. Two receivers are provided. One is fixed in the middle of the soundcard. The other is on a flying lead which plugs into the small white socket as shown on page one.

In some installations, the soundcard is visible when installed in the loco. This usually occurs when the soundcard is mounted on the floor of a cab, with or without windows. In this case, the remote control can be pointed directly at the soundcard and the on-board receiver is all that is needed.

If the soundcard is within the loco and is not visible then the flying lead needs to be used. Plug it into the white socket and glue the black receiver, round side outwards, to any external surface of the loco to which you can easily point the radio control. Do not paint the receiver.

## 7. THE REMOTE CONTROL

The soundcard will operate with any Sony™ TV remote control using the buttons described in this section. It will also operate with any universal remote control when the code is set to 0140. However your supplier has a suitable remote control illustrated here. It is a universal device which has been pre-programmed to Sony™ coding. If your remote control stops working then please refer to the Trouble Shooting Guide at the end of these instructions to re-establish the coding.

### Mute Button

- 1 Bell/Gong
- 2 Horn/Air whistle
- 3 Conductor
- 4 Brake squeal
- 5 Rail squeal
- 6
- 7 Compressor
- 8 Motor type
- 9 Automatic Mode Selection



### Start Setting

### Tickover Rate / Horn Tone

### Volume up/down

Please ensure that your chosen remote control has batteries installed. The PIFCO remote needs the code to be set to 0495.

Note that the buttons on the remote control auto-repeat if held down. If you want a single event to occur, like turning on the safety valve, then press the safety valve and release it immediately. If you want to make a large change in volume or tone then you can hold the button down to avoid the need to press the button repeatedly.

## 8. THE INFRA RED RECEIVERS

The infra-red receivers accept commands from the handheld remote control to adjust or trigger sounds. Two receivers are provided. One is fixed in the middle of the soundcard. The other is on a flying lead which plugs into the small white socket as shown on page one.

In some installations, the soundcard is visible when installed in the loco. This usually occurs when the soundcard is mounted on the floor of a cab, with or without windows. In this case, the remote control can be pointed directly at the soundcard and the on-board receiver is all that is needed.

If the soundcard is within the vehicle and is not visible then the flying lead needs to be used. Plug it into the white socket and glue the black receiver, round side

outwards, to any external surface of the loco to which you can easily point the radio control. Do not paint the receiver. When the soundcard is on the floor of the vehicle then a common practice is to drill a hole in the floor and glue the black receiver to the underside. You can then operate the TV remote by pointing it under the vehicle so that the IR signal bounces up off the sleepers and ballast.



## 9. CONFIGURING THE SOUND CARD

The soundcard has two modes:

1. Setting mode in which you can select the sounds you want and can adjust them.
2. Run mode in which the soundcard does its job on your railway.

All settings are done using the remote control and we will cover that first. So place the soundcard into Setting mode by pointing the remote control at the soundcard or the receiver on the end of the flying lead and press the **Mute** button. The LED on the soundcard will blink slowly and all sounds will cease.

Press one of the keys on the remote control to change the sounds listed below. When you press a button, the LED will start blinking faster. At any time, you can press the **Mute** button and then the button you are changing to hear the sound you have selected and then press **Mute** again to turn it off. The options are:

**Power Button – Battery or Track Power.** The soundcard can be used with battery powered, radio controlled locomotives or with locomotives which are powered from the track (but not DCC). Press this button to change from one to the other:

1 beep – Battery powered radio control.

2 beeps – Track power with a 9 volt rechargeable battery to maintain sound at low track voltage. In this case, the soundcard will automatically turn itself off when the locomotive has not moved for sixty seconds. Turning the track power up a little will turn the soundcard back on. The soundcard will automatically recharge the battery when the track voltage exceeds 10v.

3 beeps – Track power with a 7.2 volt rechargeable battery. As above except that the battery will recharge when the track voltage exceeds 8.2v and therefore at a lower speed.

**Button 0 – Country.** This is used to select the part of the world which your locomotive comes from. Your choice here will determine the default sounds which can then be changed. When you press the 0 button, one or more beeps will be heard to indicate the country currently selected as follows:

**1 beep** – Britain

**2 beeps** – North America

**3 beeps** – Australasia

**Button 1 – Bell/Gong.** This is used to select the type of bell from the list below.

**1 beep** - Bell with a high note. **(British and Australian default)**

**2 beeps** - Bell with a medium note.

**3 beeps** - Bell with a low note **(US default)**

**4 beeps** – Modern electric bell

All four bells ring once each time the button is pressed.

**Button 2 – Horn or Air Whistle.** This is used to select the style of horn which suits your vehicle. Every horn, except the Klaxon, has an adjustable pitch and volume. Each time you press the 2 button the number of beeps will increase to indicate that the horn listed below has been selected. If you wish to hear that horn, press the Mute button on the remote control and then button 2 to start the horn and then again to stop it. While the horn is sounding, you can use the channel up/down buttons to vary the pitch on horns 1 to 5 and also the volume buttons on all horns. The pre-selected horns available are:

**1 beep** – British Crich Tramway air whistle A. **(British default)**.

**2 beeps** – British Crich Tramway air whistle B.

**3 beeps** – American Peter Witt streetcar horn **(US default)**

**4 beeps** – British Manchester Metrolink horn

**5 beeps** – Sydney tram whistle **(Australian default)**

**6 beeps** – GE air horn.

**7 beeps** -- Klaxon horn

**Button 3 – Conductor.** This is used to select the conductor's sounds from the list below.

**1 beep** – Sounds a buzzer. **(British and US Default)**

**2 beeps** – Sounds "All aboard"

**3 beeps** – Sounds "All aboard" and then a double buzzer. **(Australasian Default)**

**Button 4 – Brakes.** This gives you three braking options:

**1 beep** – No braking sounds required. **(British and Australian default)**

**2 beeps** – Automatic brake squeal whenever the locomotive comes to a halt.

**3 beeps** – Automatic airbrake release when moving off

**4 beeps** – Automatic brake squeal whenever the locomotive comes to a halt plus automatic airbrake release when moving off. **(US Default)**

**Button 5 – Rail Squeal Operation.** This gives you 3 options which occur only when the vehicle is in motion:

**1 beep** – Rail squeal sounds only when function 5 is selected.

**2 beeps** – Automatic rail squeals every 30 seconds and when function 5 is selected.

**3 beeps** – Automatic rail squeals every 10 seconds and when function 5 is selected.

**4 beeps** – Automatic rail squeals every 3 seconds and when function 5 is selected. **(Default)**

**Button 6 – Rail Squeal Sound**

**1 beep** – Rail squeal 1.

**2 beeps** – Rail squeal 2.

**3 beeps** – Rail squeal 3.

**4 beeps** – Randomly selected rail squeals **(Default)**

**Button 7 – Air compressor**

**1 beep** – There is no compressor sound when the loco is stationary.

**2 beeps** – Automatic. A British Southern Electric compressor will automatically run when the loco is stationary.

**3 beeps** – Automatic. A British Metropolitan Vickers compressor will automatically run when the loco is stationary. **(British and Australian default)**

**4 beeps** – Automatic. A Birney compressor will run when the vehicle is stationary. **(US default)**

**Button 8 – Motor Type.** There are three alternative motor sounds:

**1 beep** – Motor 1

**2 beeps** – Motor 2 **(Default)**

**3 beeps** – Motor 3

All three motors can be varied in volume using the TV remote volume buttons and in pitch using the channel up/down buttons.



It is important to tell the soundcard when your loco starts moving and hence when to start revving up. Do this by slowly increasing the throttle until the loco is just about to start to move. Then press the power button on the remote control. This tells the soundcard the voltage at move off.

**Button 9 – The Operating Mode.** There are three operating modes available:

**1 beep** – Indicates manual mode. In this mode all sounds are triggered according to the above settings. The horn will sound for as long as its button is pressed.

**2 beeps** – Indicate simple automatic mode.

Automatic mode is designed for controllers which have no function buttons, as is often the case with track power, or at exhibitions, etc. where you don't want to operate manually. The horn will sound once automatically when the loco moves off and then once more three times a minute when the loco is on motion. A reed switch can be placed under the loco and be connected to the F1 terminal to make the bell sound when the loco passes over a magnet. Another reed switch, connected to the F2 terminal, can be used to trigger the horn which will turn on when crossing a magnet and then off at the next magnet.

You can change these settings whenever you wish, and those changes will be effective immediately.

## 9. OPERATING THE SOUND CARD

When the tram is running, the motor sounds should operate automatically, getting louder when accelerating and softer when slowing down or idle.

Where your controller has function buttons they can be connected to the function terminals as follows:

- Terminal 1. Sounds the bell/gong.
- Terminal 2. Operates the horn or air whistle.
- Terminal 3. Sounds "All aboard" and/ or the conductor's buzzer.
- Terminal 4. Sounds an airbrake release.
- Terminal 5. Rail squeal.

## 10. TROUBLE SHOOTING GUIDE

### THE REMOTE CONTROL WON'T WORK

Press any button. If a red light does not flash next to the TV button then the battery is missing. If it flashes twice then the battery is flat and the remote control is not sending anything. Slide open the battery compartment and insert two new AAA cells. Then, when you press a button, the red light should flash once to indicate that it is sending.

If the remote still does not work then the Sony™ coding may have been lost. Hold down the SET button for about four seconds until the red light stays on. Press and release the 0, then the 1, then the 4 and then the 0 button in turn. The red light will then go out and the remote control is then ready for use.

If the remote control still does nothing then the problem may be the infra-red receiver on the loco which must not be painted or obstructed.

### I GET NO SOUND AT LOW SPEEDS WHEN USING TRACKPOWER

On trackpower, you may get no sound at low speeds until the track voltage gets up to about nine volts. This indicates that the support battery is flat. Charge it by running the loco at speed for ten minutes.

### I GET NO SOUND AT ALL

Press the Mute button on the remote control in case the sound has been accidentally turned off.

Switch the loco off and then on again. When the soundcard starts, the LED should flash once. If not then use a multimeter to check that there is at least nine volts at the B+ and B- terminals. If not then check your wiring in case something has come adrift.

Check that the speaker is connected correctly or try a different speaker.

### THE SOUND CARD MAKES A CLICKING NOISE OR SHUTS DOWN

This most often occurs when the horn is sounded. It is caused by the soundcard restarting because there is insufficient voltage in the track or the battery to sustain the volume setting. Recharge the battery.

### WHEN INSTALLED IN A LOCO, THE SOUND STOPS INTERMITTENTLY AND I HAVE TO RESET THE CONTROLLER TO GET IT GOING AGAIN

The soundcard maximum output is 1.5 amps. If this is exceeded as a result of a short circuit, a heavy load and/or high volume settings then the soundcard will shut down. Also, if the soundcard is installed in a very confined space and is run for a prolonged period at high power then it can overheat and switch itself off while it cools down.

### HOW TO RESET YOUR SOUND CARD

A time may come when you have been adjusting the sound and you want to start again. This can be achieved by resetting the soundcard back to the settings when it left the factory. You can do this by pressing the 0 button on the remote control and hold it down for three seconds. The soundcard will beep five times when the reset is complete.

## 11. USING AN EXTERNAL AMPLIFIER FOR RIDE ON RAILWAY LOCOMOTIVES

When used in 5 inch and 7¼ inch ride on railways there is a lot of environmental noise. The output of the soundcard alone is not sufficient for these environments and an external amplifier needs to be used. The wiring diagram overleaf shows how the soundcard can be interfaced to a commercial stereo amplifier in a vehicle with 24v motors powered by two 12 V batteries.

Note that the soundcard can handle a maximum of 24 volts DC. A battery which is labelled as 24 volts will typically output 28 volts when fully charged and will therefore damage the soundcard if connected directly. The two 10K resistors on the M1/M2 terminals keep the voltage down to 24v.

In Australia, the 2x15 watt AA0487 amplifier from Jaycar is suitable. Other amplifiers may require the 100Ω resistor to be changed. If the output volume is too low then raise the value of the 100Ω resistor.

A single speaker can be used on the right output or two speakers on the left and right outputs.

Any of the five functions can be used by means of a pushbutton between the function terminal and ground. The sound functions available are horn, bell, guard's whistle, airbrake release and engine start/stop. Only the horn wiring is shown in the diagram.

The installation can be made more robust by enclosing the soundcard, capacitor and two resistors into a plastic project box as shown in the diagram. The whole can then be fixed to the top of the amplifier using silicon.

Select a speaker which matches the impedance and power output of the amplifier. In the case of the Jaycar AA0487 a 15 watt speaker of four ohms impedance is needed. It is also important to make a soundbox which is an airtight fit to the back of the speaker. This will improve both volume and sound quality.

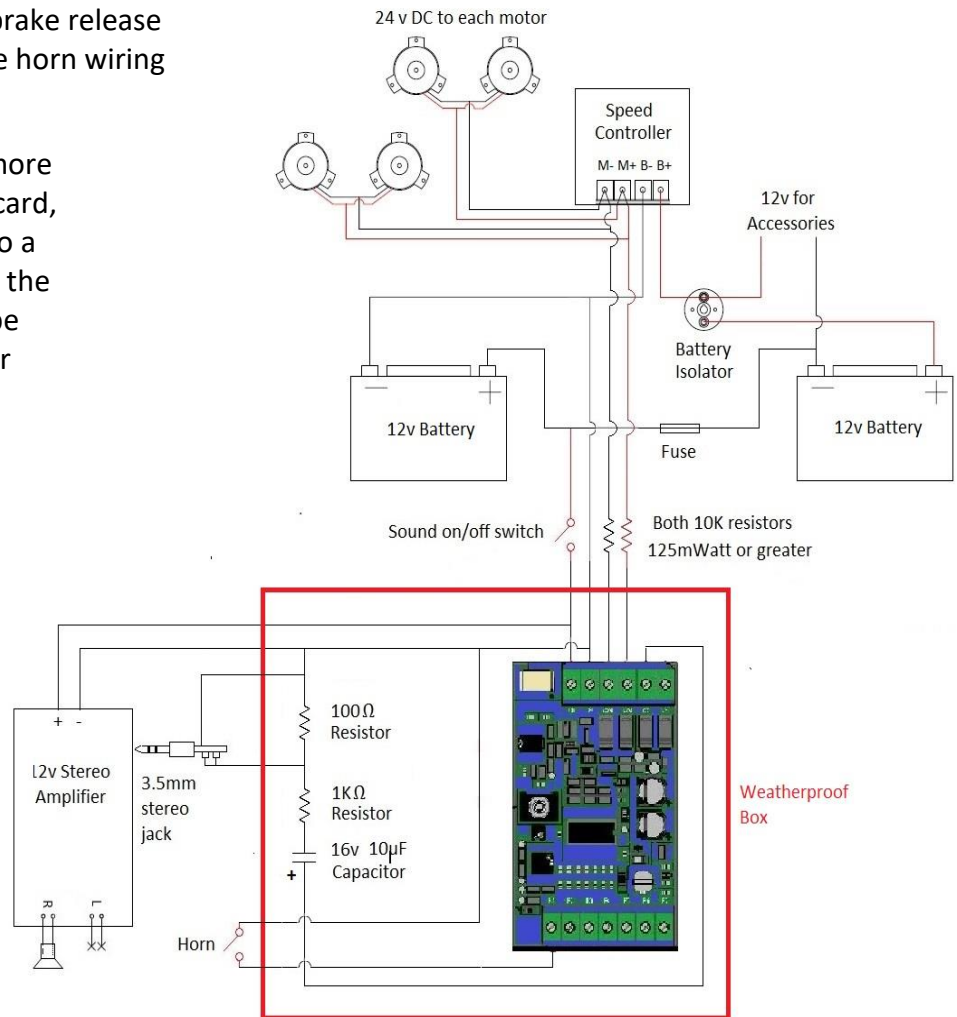

For more information, please visit the web site at [www.mylocosound.com](http://www.mylocosound.com) or e-mail [sales@mylocosound.com](mailto:sales@mylocosound.com).

Remote Control	Radio Control	Defaults shown in grey	
<b>Power</b>		Set Start Voltage for Rev Up	
<b>VOL up/down</b>		Change Volume of active sound	
<b>CH up/down</b>		Change Sound	Horn Tone when horn sounding
			Motor tone when moving
<b>Mute</b>		Sound on/off	
<b>Button 1</b>	<b>F1</b>	Warning bell	
<b>Button 2</b>	<b>F2</b>	Horns and whistles	
<b>Button 3</b>	<b>F3</b>	All Aboard or Guard's buzzer	
<b>Button 4</b>	<b>F4</b>	Brake release/squeal	
<b>Button 5</b>	<b>F5</b>	Rail squeal	
<b>Button 6</b>	<b>F6</b>		
<b>Button 7</b>		<b>Compressor Type</b>	
		1 beep	No compressor
		2 beeps	British Southern Electric compressor
		3 beeps	Metro Vick compressor
		<b>4 beeps</b>	Birney compressor
<b>Button 8</b>		<b>Engine Sound</b>	
		1 beep	Motor 1
		2 beeps	Motor 2
		3 beeps	Motor 3
<b>Button 9</b>		<b>Control Mode</b>	
		1 beep	Manual
		2 beeps	Auto horn every 20 secs
	<b>F7</b>	Not used	
<b>Button 0 Held For more than 5 seconds</b>		Reset above settings to defaults	