

# MYLOCOSOUND CLASSIC

SOUND FOR LARGE SCALE STEAM LOCOMOTIVES

North  
American  
Edition

## 1.OVERVIEW

- Easy installation using screw terminals with no soldering.
- Uses a TV remote control to adjust the volume and sounds to match the prototype loco.
- Provides a chuff sound which matches the loco speed and load.
- Five recorded hooter, 3, 5 and 6 chime whistles
- Selectable sounds include whistle, bell, safety valve, "All aboard", brake pump, rod clank, drain cocks and brake squeal.
- For track powered DC or battery powered, radio controlled railways

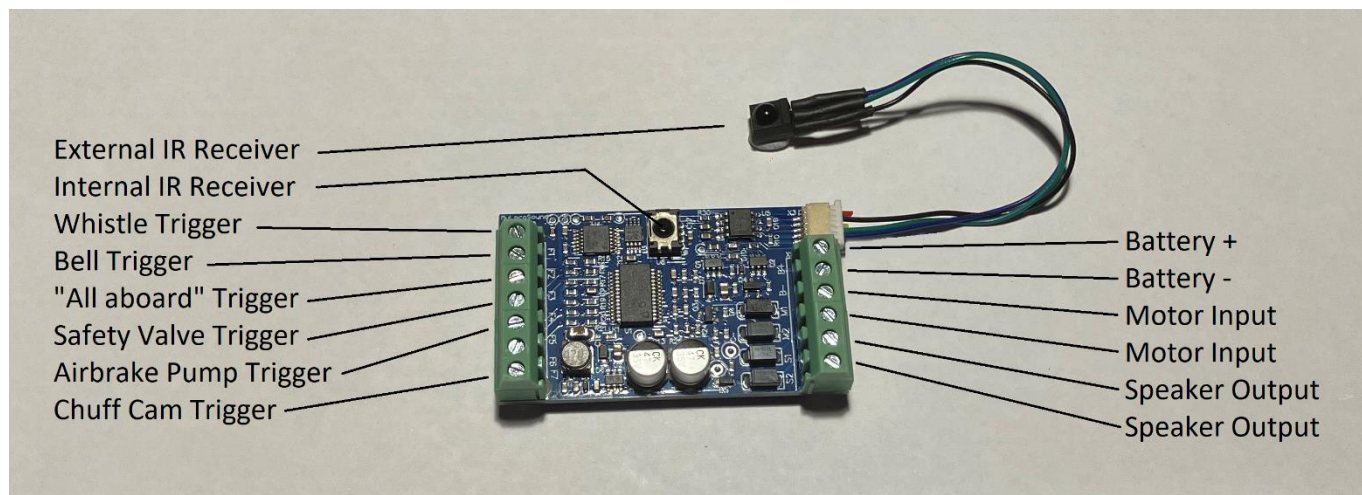

configuring the soundcard

### Important

**The soundcard is designed for outdoor use and may not work correctly under bright incandescent lights on a workbench. Some LED lights may have color settings which will also cause issues.**

**The soundcard is in a "sleep" mode when not in use. Connecting it to power at the B+ and B- terminals will not wake it up. It must also be connected to a motor at the M1 and M2 terminals as well. The small voltage it sees at the motor will wake it up and it will then stay awake for as long as it has power.**

**4. INSTALLING THE SOUNDCARD IN A TRACK POWERED LOCOMOTIVE, DC OR DCC**

The soundcard is suitable for use on analogue DC track powered railways on which the following wiring

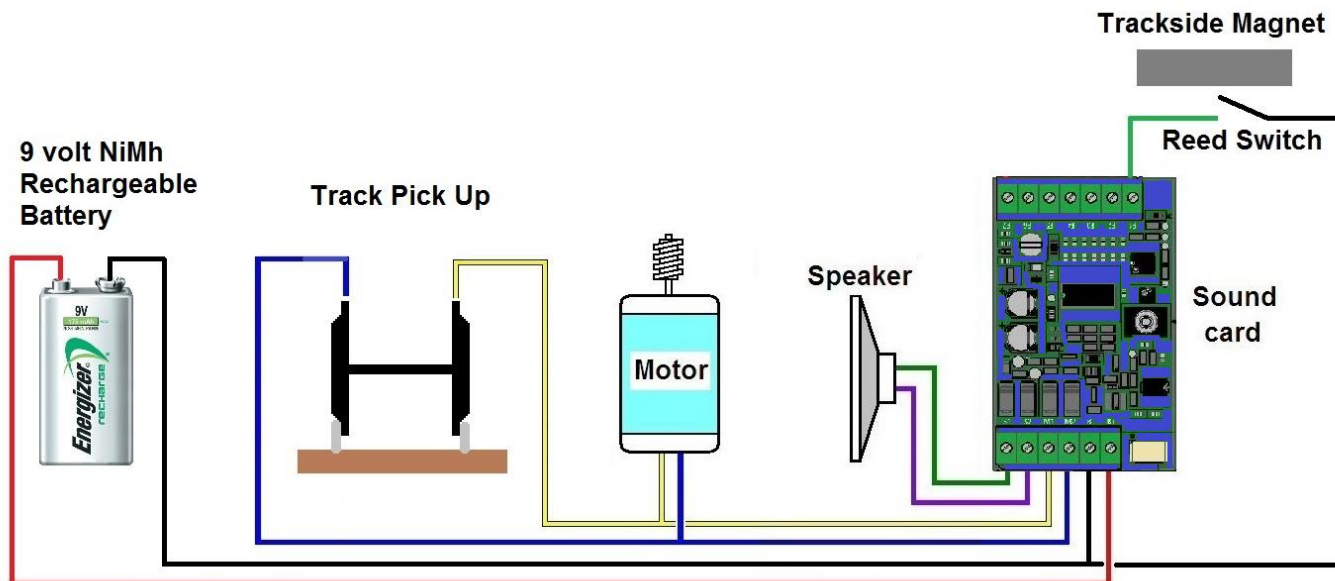

The wiring diagram below shows the connections for the DC jumper board in a Bachmann locomotive.

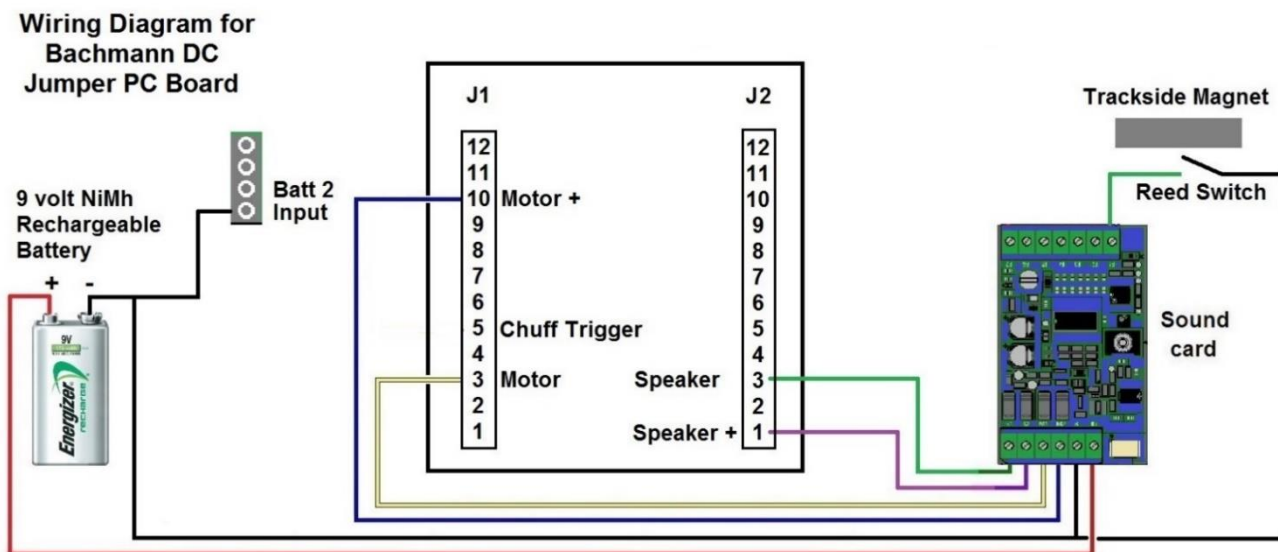

When the motor voltage is below seven volts it is insufficient to power the soundcard. Therefore a 9v volt PP3 or a 7.2v cordless phone battery is used to drive the soundcard and produce sound when the loco is static or moving slowly. This battery will be automatically recharged whenever the motor voltage is at about 1.8 volts higher than the battery voltage so there should never be a need to remove the battery for recharging. However, the battery must be a Nickel Metal Hydride type; Lithium and Nickel Cadmium batteries must not be used. On small shunting layouts, the loco speed is often not high enough for charging to take place. Some owners of shunting layouts put an isolation switch on the loco motor circuit so that they can turn up the power to recharge the battery without having the loco moving.

On analogue DC layouts which have pure DC controllers (as opposed to PWM controllers) you may need to give the throttle a bit of a tweak to start the sound. On those layouts, the sound will automatically turn off

after one minute of inactivity and another tweak will turn it back on. With the more common PWM controllers and with DCC the sound will turn on automatically and stay on.

When the loco is removed from the track the soundcard will go into a “sleep” mode to preserve the battery charge. A fully charged battery should retain charge for over a year.

Because most DC controllers do not have function buttons, an alternative way of triggering the horn and other sounds needs to be found. The options are:

1. You can set the whistle to sound automatically three times a minute when the train is running. Other sounds can also be triggered automatically. This is described in section 11.
2. You can connect the soundcard whistle trigger to a reed switch which you mount on the bottom of the loco. Then install magnets in the track where you want the horn to sound eg. at the approaches to a level crossing. The horn will then sound briefly as the loco crosses each magnet.
3. Use the remote control, supplied with the soundcard, to trigger all the sounds as described in section 11. However, infra-red remote controls are not designed for long distance use outside. On an overcast but bright day, the remote control, powered by AA or AAA batteries will probably operate up to three metres away.

Any combination, or all, of these methods can be used.

With DCC, the soundcard is not a decoder and cannot trigger sounds directly from the controller. Therefore the above methods are used to trigger the sounds. Some decoders have a servo output which can be used to trigger sounds from the controller buttons by using a servo switch. They may also have a constant DC power output which can replace the battery if it is in the voltage range 8 to 24 volts. These connection options are shown below:

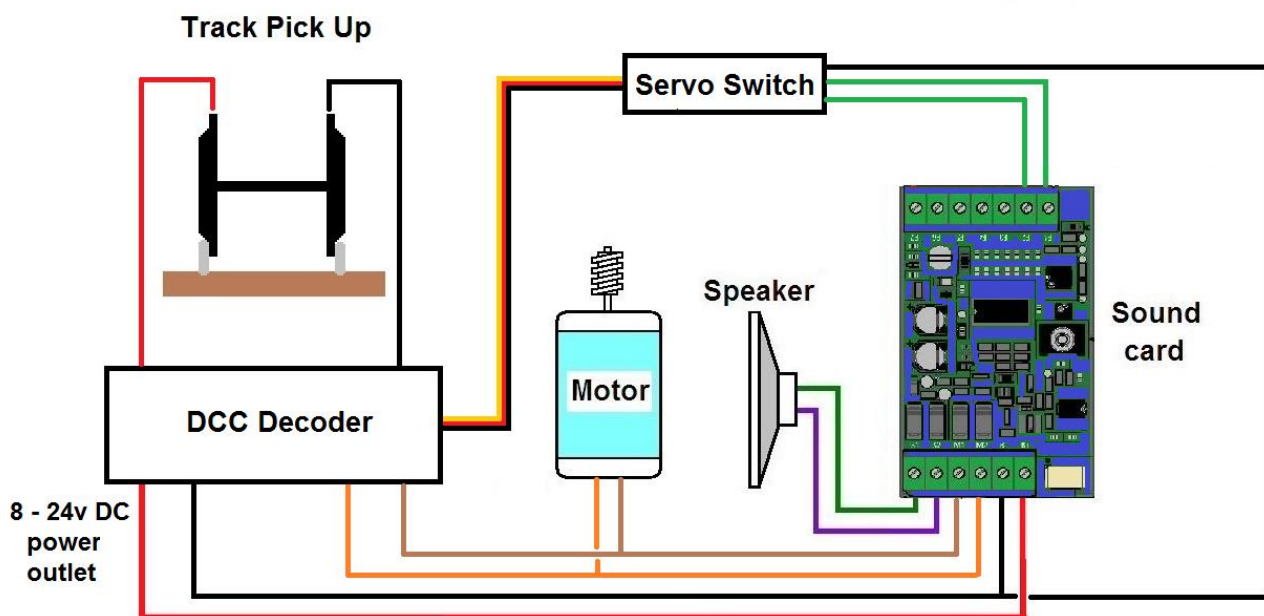

Many decoders also have function outputs which can be used to trigger sounds. However, this is technically difficult and you should only attempt it if you are very familiar with your decoder and the setting of CVs.

Now continue reading at section 7.

### 5. INSTALLING THE SOUND CARD IN A BATTERY POWERED LOCOMOTIVE OR RAILCAR

The wiring diagram below shows a typical installation for common types of battery powered radio control systems.

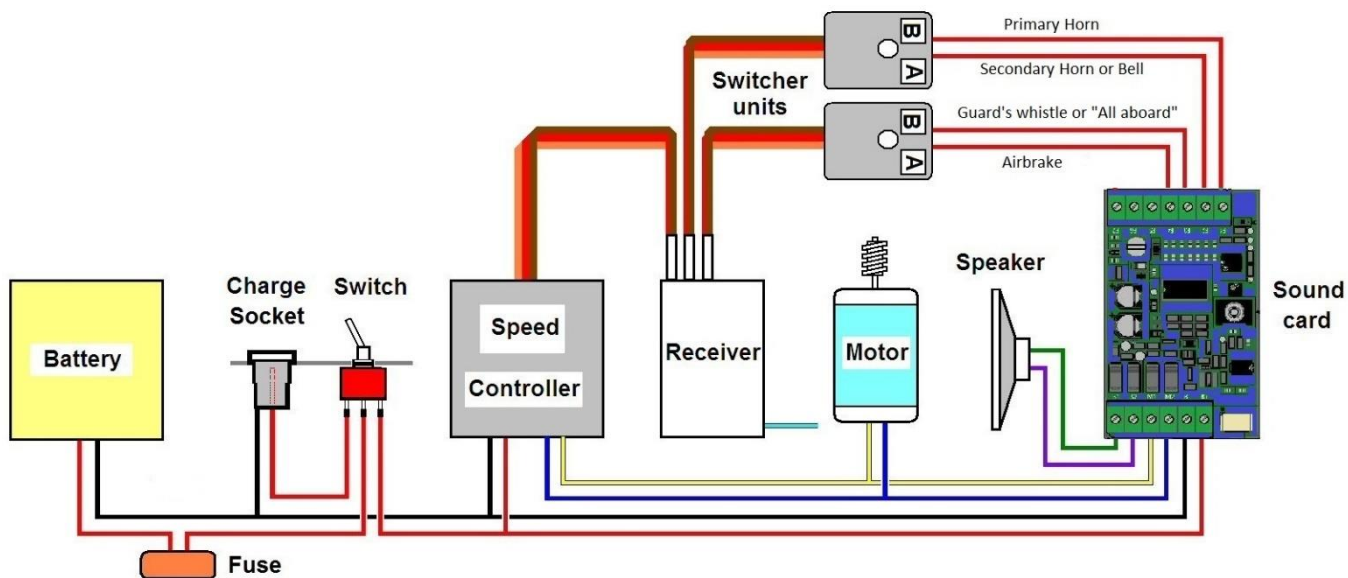

The receiver shown has two function channels, each of which can operate two triggers via two switcher units. The fifth soundcard trigger, the turbocharger, therefore cannot be radio controlled and will need to be switched on, if required, by the IR remote control. A suitable switcher unit is the Pololu 2804.

The above wiring diagrams can be seen in colour by visiting the web site at [www.mylocosound.com](http://www.mylocosound.com) and select the 'How to Install' menu. Also shown are specific wiring diagrams for Fosworks, Deltang, RCS, Railboss, Revolution, Localinc and others.

### 6. INSTALLING THE SOUND CARD WITH NO MOTOR

Steam sound effects can be added to live steam locomotives using the wiring below:

A single radio control receiver, regulator and reverser selected sounds using the

If you wish the soundcard to produce chuff sounds for the wheels, a chuff switch is needed. Glue four small magnets at ninety degree intervals around the back of one driving wheel. Then position a reed switch close to the wheel so that the switch closes each time a magnet passes.

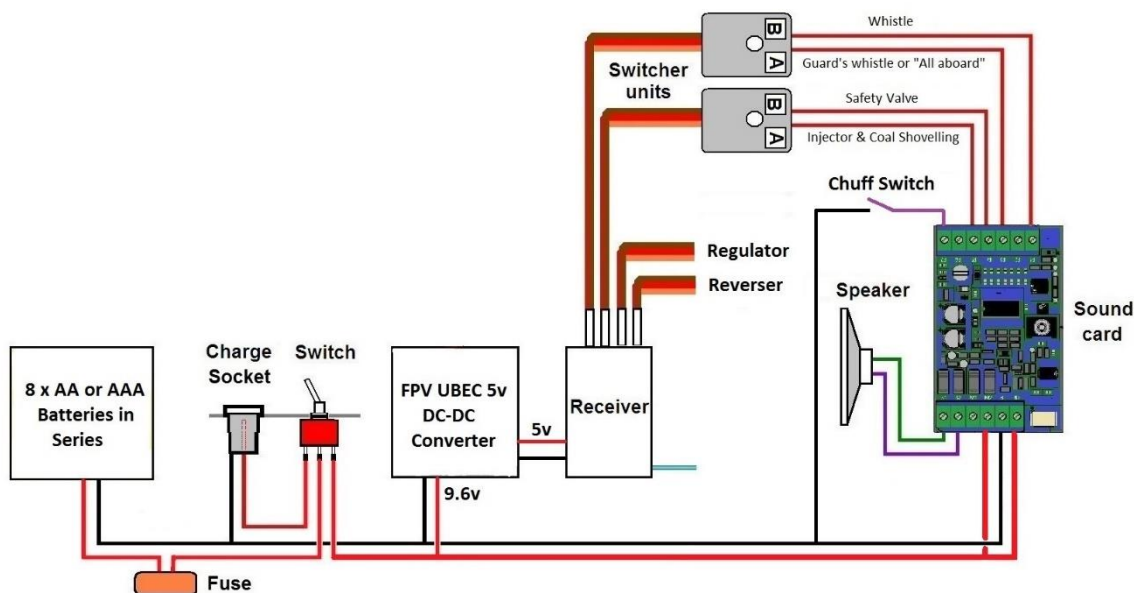

passes. The soundcard will then chuff four times per wheel revolution.

A simple sound installation, which will drop into a locomotive tender or trailing van, can be achieved using the wiring alongside:

A chuff switch can be set up on the tender or van wheels. The soundcard automatic modes can be used to make a whistle sound on departure and at timed intervals. Other sounds can also occur automatically using the modes provided. A rechargeable PP3 battery should sustain continuous running with an automatic whistle for about two hours.

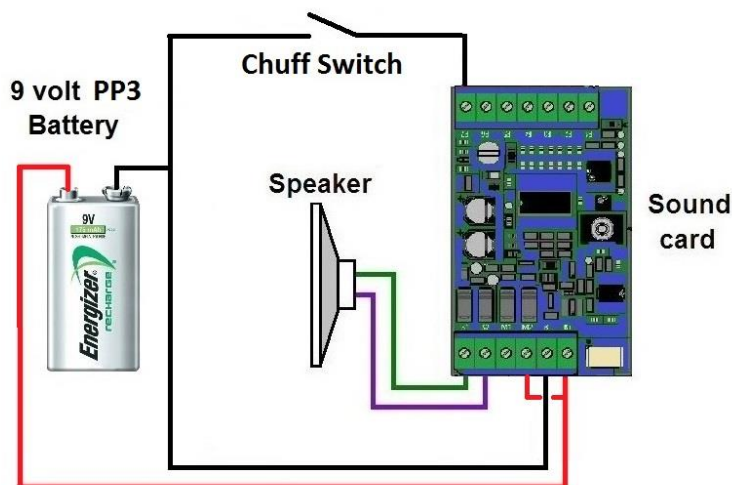

The most common way of doing a chuff switch is to use a reed switch positioned close to the back of a tender or van wheel and then glue magnets around the back of the wheel as follows:

The wheel is the same diameter as the loco driving wheels

4 magnets 90° apart

The wheel is three quarters the diameter of the loco driving wheels

3 magnets 120° apart

The wheel is half the diameter of the loco driving wheels

2 magnets 180° apart

## 7. THE INFRA-RED RECEIVERS

The infra-red receivers accept commands from the handheld remote control to adjust or trigger sounds. Two receivers are provided. One is fixed in the middle of the soundcard. The other is on a flying lead which plugs into the small white socket as shown on page one.

In some installations, the soundcard is visible when installed in the loco. This usually occurs when the soundcard is mounted on the floor of a cab, with or without windows. In this case, the remote control can be pointed directly at the soundcard and the on-board receiver is all that is needed.

If the soundcard is within the loco and is not visible then the flying lead needs to be used. Plug it into the white socket and glue the black receiver, round side outwards, to any external surface of the loco to which you can easily point the radio control. Do not paint the receiver. When the soundcard is on the floor of the vehicle then a common practice is to drill a hole in the floor and glue the black receiver to the underside. You can then operate the TV remote by pointing it under the vehicle so that the IR signal bounces up off the sleepers and ballast.



## 8. THE REMOTE CONTROL

The soundcard will operate with any Sony™ TV remote control using the buttons described in this section. It will also operate with any universal remote control when the code is set to 0140. However your supplier has a suitable remote control illustrated here. It is a universal device which has been pre-programmed to Sony™ coding. If your remote control stops working then please refer to the Trouble Shooting Guide at the end of these instructions to re-establish the coding.

Please ensure that your chosen remote control has batteries installed. The PIFCO remote needs the code to be set to 0495.

Note that the buttons on the remote control auto-repeat if held down. If you want a single event to occur, like turning on the safety valve, then press the safety valve and release it immediately. If you want to make a large change in volume or tone then you can hold the button down to avoid the need to press the button

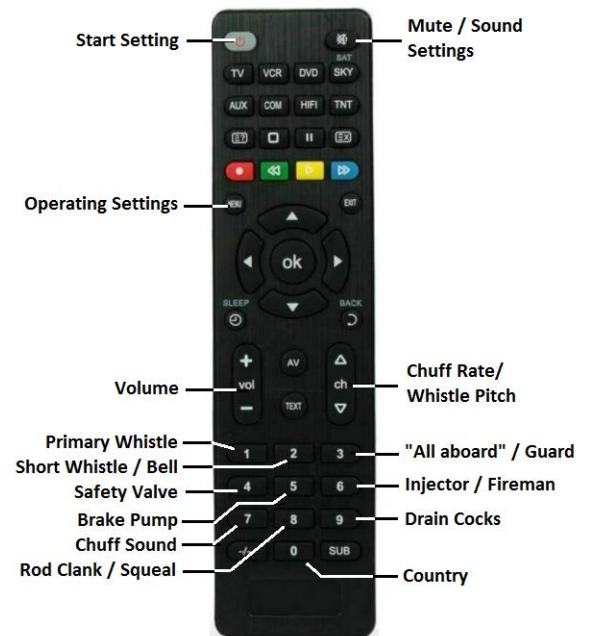

The soundcard has three modes:

1. **Sound setting** mode in which you can select the sounds you want by pressing the Mute button.
2. **Operating setting** in which you can choose the way the sounds are triggered by pressing the Enter button.
3. Run mode in which the soundcard does its job on your railway.

All sound settings are done using the TV remote control and we will cover that first. To place the soundcard into Sound Setting mode point the remote control at the soundcard or the receiver on the end of the flying lead and press the **Mute** button. The LED on the soundcard will blink slowly and all sounds will cease. Next press one of the keys on the remote control and the number of beeps will indicate the current sound setting as listed below. Press the key again and the setting will move to the next sound listed below. At any time, you can press the **Mute** button to hear the sound you have selected or to return to run mode.

All operating settings are also done using the TV remote control. To place the soundcard into Operating Setting mode point the remote control at the soundcard or the receiver on the end of the flying lead and

Note: Some TV remotes do not have an **Enter** button or they have an **Enter** button which the soundcard is unable to understand. If you hit this problem then you can get into Operating Settings by doing the following:

- Press **Mute** to get into Sound Setting. The LED will blink slowly.
- Press the Zero button.
- You will now be in Operating Setting. The LED will blink fast.
- When you are done, press **Mute** to return to Sound Setting.
- Press **Mute** again to return to run mode.

press the **Enter** button. The LED on the soundcard will blink fast and all sounds will cease. Next press one of the keys on the remote control to indicate the current operating mode and again to move through the options listed below. At any time, you can press the **Enter** button to return to run mode.

The volume of all sounds can be varied by using the volume up/down buttons on the TV remote while that sound is playing.

All settings are listed in a quick reference table on the last page of these instructions.

## 8. SOUND SETTING OPTIONS (MUTE BUTTON)

**Power Button – Chuff Sensitivity.** As you throttle up and down to change the speed of the locomotive, the chuff sound will change. It will be loud when accelerating, softer when coasting and faint when decelerating. Press this button to change the sensitivity of the chuff to throttle changes as indicated by the number of beeps when pressed. One beep indicates maximum sensitivity. Five beeps sets minimum sensitivity ie. the chuff will not change. The default sensitivity is two and change to one if you want more sensitivity or three or more if the chuff sounds erratic. One beep is recommended for pushbutton throttles.

**Button 0 – Not used in sound setting.**

**Button 1 – Whistle.** This is used to select the style of whistle which suits your locomotive. Every one of these whistles has an adjustable volume. Each time you press the 1 button the number of beeps will increase to indicate that the whistle listed below has been selected. If you wish to hear that whistle, press the Mute button on the remote control to reactivate the sound then press the 1 button to start the whistle and then again to stop it. The pre-selected whistles available are:

<b>Beeps</b>	
1	Hooter whistle
2	3 Chime whistle A
3	3 Chime whistle B
4	5 Chime whistle
5	6 Chime whistle ( <b>Default</b> )

**Button 2 – Bell or alternate whistle**

- 1 beep** – Sounds the brass bell
- 2 beeps** – Sounds the bronze bell (**Default**)
- 2 beeps** – Sounds a short whistle

**Button 3** – Will sound “All aboard”

**Button 4** – Not used in sound setting.

**Button 5** – Will sound the Airbrake compressor pump

- 1 beep** – Sounds a slow pump (**Default**)

**Button 6** – Not used in sound setting.

**Button 7 – Locomotive chuff sound in motion**

**1 beep** – Deep chuff for a heavy locomotive **(Default)**

**2 beeps** – Sharper chuff for a small locomotive

**Button 8 – Deceleration sounds**

**1 beep** – Brake squeal as it stops **(Default)**

**2 beeps** – Rod clank when slowing down

**3 beeps** – Both brake squeal and rod clank

Note that the rod clank is only audible when the loco has stopped chuffing when slowing down.

**Button 9** – Not used in sound setting.

## 9. OPERATING SETTING OPTIONS (ENTER BUTTON)

**Power Button – Battery or Track Power.** The soundcard can be used with battery power, with or without a locomotive, or with locomotives which are powered from the track. Press this button to switch:

**1 beep** – Battery power. **(Default)**

**2 beeps** – Track power with a 9v support battery. The soundcard will automatically turn itself off when the locomotive has not moved for sixty seconds. Turning the power up a little will turn the soundcard back on. The support battery will automatically recharge when the track voltage exceeds 10v.

**3 beeps** – Track power with a 7.2v support battery. The soundcard will automatically turn itself off when the locomotive has not moved for sixty seconds. Turning the power up a little will turn the soundcard back on. The support battery will automatically recharge when the track voltage exceeds 8v.

**Button 0** – Not used in mode setting

**Button 1 – Whistle operation options.** There are three whistle operating modes available:

**1 beep** – Indicates manual operation. In this mode all sounds are triggered by manual press of the TV remote button or by Function 1. With battery radio control, the whistle will sound for as long as function 1 is closed. With track power the whistle will sound for one second when function 1 is triggered by track magnets. **(Default)**

**2 beeps** – Indicate simple automatic mode. This is designed for controllers which have no function buttons, as is often the case with track power, or at exhibitions, etc. where you don't want to operate manually. The whistle will sound once automatically when the loco moves off and then once more three times a minute when the loco is on motion. A reed



switch can be placed under the loco and be connected to the F1 terminal to make the whistle sound when the loco passes over a magnet. Another reed switch, connected to the F2 terminal, can be used to trigger the bell. If the bell is set to one beep then it will ring continuously until the loco passes over another magnet. If the bell is set to two beeps then it will ring for the set time.

**3 beeps** – Indicate American automatic mode. Again this is designed for controllers which have no function buttons, as is often the case with track power, or at exhibitions, etc. where you don't want to operate manually. However, it follows American rules. The whistle will sound two long toots when the loco moves off forwards or three short when backing up. If these occur the wrong way around then reverse the leads at the M1/M2 terminals. When the loco stops, a single short toot will indicate brakes on. A reed switch can be placed under the loco and be connected to the F1 terminal to make the whistle sound the grade crossing sequence when the loco passes over a magnet. Another reed switch, connected to the F2 terminal, can be used to trigger the bell. If the bell is set to one beep then it will ring until the loco passes over another magnet. If the bell is set to two beeps then it will ring for the set time.

**Button 2 – Bell operations.** This is used to select the bell operation from the list below.

- 1 beep** – Manual bell. Starts ringing repeatedly when the button is pressed until the button is pressed again.
- 2 beeps** – Timed bell. When F2 is triggered, rings repeatedly for a predetermined time. To set that time, press the Mute button to exit setting mode and then press Button 2 to ring the bell. When the bell has rung for as long as you want, press Button 2 again to stop the ringing. The time is then set and the bell will ring for that time when F2 is triggered while running.
- 3 beeps** – Automatic bell. Rings repeatedly when the motor voltage is less than 4 volts. **(US Default)**
- 4 beeps** – Automatic bell. Rings repeatedly when the motor voltage is less than 8 volts.
- 5 beeps** – Automatic bell. Rings repeatedly when the motor voltage is less than 12 volts.
- 6 beeps** – Manual bell. Rings once only each time the button is pressed. **(Australasian Default)**

**Button 3** – Sounds the “All aboard” each time the TV remote button 3 or function 3 is triggered.

**Button 4 – Safety Valve.** This will operate in four ways:

- 1 beep** – Manual. Starts blowing when the button is pressed or F4 is triggered and stops when pressed again.
- 2 beeps** – Throttle controlled. When the loco is stationary, turn the throttle up a little and the safety valve will blow off until you turn the throttle off or forwards to move off. For this to work, the chuff start must first be set as described below.
- 3 beeps** – Automatic. Blows for 10 seconds once a minute.
- 4 beeps** – Automatic. Blows for 10 seconds once every 2 minutes. **(Default)**

**Button 5 – Westinghouse Brake Pump.** This will operate in two ways:

- 1 beep** – Manual. Sounds only if the TV remote 5 button is pressed or function 5 is triggered.
- 2 beeps** – Automatic. Sounds whenever the locomotive is stationary.
- 3 beeps** – Automatic. Sounds for 20 secs every minute when the locomotive is stationary. **(Default)**

**Button 6** – Not used in operating setting.

**Button 7 – Steam Chuff.** The locomotive chuff can be generated in three ways:

**1 beep** – Automatic chuff based on the motor voltage for two or four cylinders. **(Default)**

**2 beeps** – Automatic chuff based on the motor voltage for locomotives with three cylinders.

**3 beeps** – Mechanically triggered chuff. For locomotives which have an electric motor and a built in chuff trigger on an axle. The output from that chuff trigger needs to be connected to the F7 terminal on the soundcard. Note that the chuff trigger will function only when there is a voltage the M1/M2 terminals.

**4 beeps** – Mechanically triggered chuff. For locomotives which **do not** have an electric motor but have a built in chuff trigger on an axle. The output from that chuff trigger needs to be connected to the F7 terminal on the soundcard. See section 6 above for the wiring.

When automatic chuff is selected, the chuff needs to be set to correctly match the loco. This is done with the sound active. Starting from static, turn up the throttle until the loco just starts moving and then press the Power button on the remote control. This will set the voltage at which the chuff starts.

Next the chuff rate needs to be set to four or three beats per wheel revolution depending on the number of cylinders as above. Before doing this step it is a good idea to turn off all other sounds so that you can clearly hear the chuff alone. Then throttle up the loco so that it is running at a scale walking pace and use the channel up/down buttons on the remote to adjust the chuff rate to the correct number of beats per revolution. When you are satisfied then restore the other sounds.

A customer, Rik Bennett, has made an excellent video of setting the chuff which can be seen by going to YouTube and searching for “MyLocoSound steam setting”. It can also be accessed through the steam page at [www.mylocosound.com](http://www.mylocosound.com).

**Button 8 – Brake Squeal.** This will operate in these ways:

**1 beep** – Not required. **(Default)**

**2 beeps** – Automatic with the clank, if selected, sounding when the motor voltage is 6 to 12 volts.

**3 beeps** – Automatic with the clank, if selected, sounding when the motor voltage is 4 to 8 volts.

**4 beeps** – Automatic with the clank, if selected, sounding when the motor voltage is 3 to 6 volts.

**Button 9 – Drain cocks.** When a locomotive has been static for a while water condenses in the cylinders and can cause damage as a result of priming. When the locomotive moves off the driver will open the drain cocks for a short time and the chuff will be replaced with a hiss. There are three options:

**1 beep** – Not required. **(Default)**

**2 beeps** – Automatic for ten seconds after a one minute stop.

**3 beeps** – Automatic for ten seconds after a three minute stop

**Resetting the soundcard back to factory default settings.** If you get in a bit of mess and want to start again then you can reset the soundcard by holding down the 0 (zero) button of the remote control for three seconds. You will then hear five beeps and all settings will revert to the defaults for the country you have

selected. These include the default sounds, 2/4 cylinders and a voltage controlled chuff. It will not change the country.

You can change all the above settings whenever you wish and the changes will be effective immediately.

## 12. OPERATING THE SOUND CARD

**When the loco is running, the engine sounds should operate automatically, getting louder when accelerating and softer when slowing down or idle.**

Where your controller has function buttons then you can use them as follows to trigger terminals F1 to F6:

- Terminal F1. Sounds the main whistle. On track power the whistle will sound for one second so that it can be triggered by track magnets. On radio control the whistle sounds for as long as the function is triggered.
- Terminal F2. Operates the bell for as long as the button is pressed.
- Terminal F3. Sounds the "All aboard".
- Terminal F4. Sounds the safety valve blowing off.
- Terminal F5. Switches the Westinghouse brake pump when manual mode has been selected.

## 13. TROUBLE SHOOTING GUIDE

### THE REMOTE CONTROL WON'T WORK

Start the soundcard, press any button on the remote control and the LED on the remote should flash. If it does not flash then the battery probably needs replacing. If the battery is okay then try stretching the battery contact springs and then replace the battery.

If the LED flashes but the soundcard does not respond then the Sony™ coding may have been lost and can be reset as follows.

Refer to the remote control's instructions for resetting the Sony coding. You will probably find a number of codes listed for Sony and will need to try each one until you get to the code which operates the soundcard volume, mute and function buttons correctly. For the Brightstar, hold down the Setup button until the LED comes on and then enter 605. The LED will go off and it is ready for use.

If the remote control still does nothing then the problem may be the infra-red receiver on the loco which must not be painted or obstructed.

### I GET NO SOUND AT LOW SPEEDS WHEN USING TRACKPOWER

On trackpower, you may get no sound at low speeds until the track voltage gets up to about nine volts. Indicates that the support battery is flat. Charge it by running the loco at a track voltage greater than ten volts for ten minutes.

### I GET NO SOUND AT ALL

Switch the loco off and then on again. When the soundcard starts, the LED should flash once. If not then use a multimeter to check that there is at least nine volts at the B+ and B- terminals and the M1/M2

voltage is greater than zero to wake up the soundcard. If not then check your wiring in case something has come adrift. Check that the speaker is connected correctly.

If you are bench testing and there is a light shining on circuit board then this can put the soundcard into factory programming mode and stop the sound. In that case, the yellow LED next to the F1 terminal will stay on. You can fix this by covering the IR receiver on the soundcard and on the flying lead, if fitted.

---

#### **THE SOUND CARD MAKES A CLICKING NOISE OR SHUTS DOWN**

This most often occurs when the whistle is sounded. It is caused by the soundcard restarting because there is insufficient voltage in the track or battery to sustain the volume setting. Recharge the battery.

---

#### **WHEN INSTALLED IN A LOCO, THE SOUND STOPS INTERMITTENTLY AND I HAVE TO RESET THE CONTROLLER TO GET IT GOING AGAIN**

The soundcard maximum output is 1.5 amps. If this is exceeded as a result of a short circuit, a heavy load and/or high volume settings then the soundcard will shut down. Also, if the soundcard is installed in a very confined space and is run for a prolonged period at high power then it can overheat and switch itself off while it cools down.

---

#### **HOW TO RESET YOUR SOUND CARD**

A time may come when you have been adjusting the sound and you want to start again. This can be achieved by resetting the soundcard back to the settings when it left the factory. You can do this by pressing the 0 button on the remote control and hold it down for three seconds. The soundcard will beep five times when the reset is complete.

---

#### **MY RADIO CONTROL HAS BECOME ERRATIC**

If the soundcard is installed very close to the loco radio receiver e.g. back to back, then it can interfere with the radio commands and operation can become erratic. To avoid this problem move the soundcard a little away from the receiver.

### **14. USING AN EXTERNAL AMPLIFIER FOR RIDE ON RAILWAY LOCOMOTIVES**

When used in 5 inch and 7¼ inch ride on railways there is a lot of environmental noise. The output of the soundcard alone is not sufficient for these environments and an external amplifier needs to be used. The wiring diagram overleaf shows how the soundcard can be interfaced to a commercial stereo amplifier in a loco with 24v motors powered by two 12 V batteries.

Note that the soundcard can handle a maximum of 24 volts DC. A battery which is labelled as 24 volts will typically output 28 volts when fully charged and will therefore damage the soundcard if connected directly. The two 10K resistors on the M1/M2 terminals keep the voltage down to 24v.

In Australia, the 2x15 watt AA0487 amplifier from Jaycar is suitable. Other amplifiers may require the 100Ω resistor to be changed. If the output volume is too low then raise the value of the 100Ω resistor.

A single speaker can be used on the right output or two speakers on the left and right outputs.

Any of the five functions can be used by means of a pushbutton between the function terminal and ground. The sound functions available are horn, bell, guard's whistle, airbrake release and engine start/stop. Only the horn wiring is shown in the diagram. The installation can be made more robust by enclosing the soundcard,

capacitor and two resistors into a plastic project box as shown in the diagram. The whole can then be fixed to the top of the amplifier using silicon. Select a speaker which matches the impedance and power output of the amplifier. In the case of the Jaycar AA0487 a 15 watt speaker of four ohms impedance is needed. It is also important to make a soundbox which is an airtight fit to the back of the speaker. This will improve both volume and sound quality.

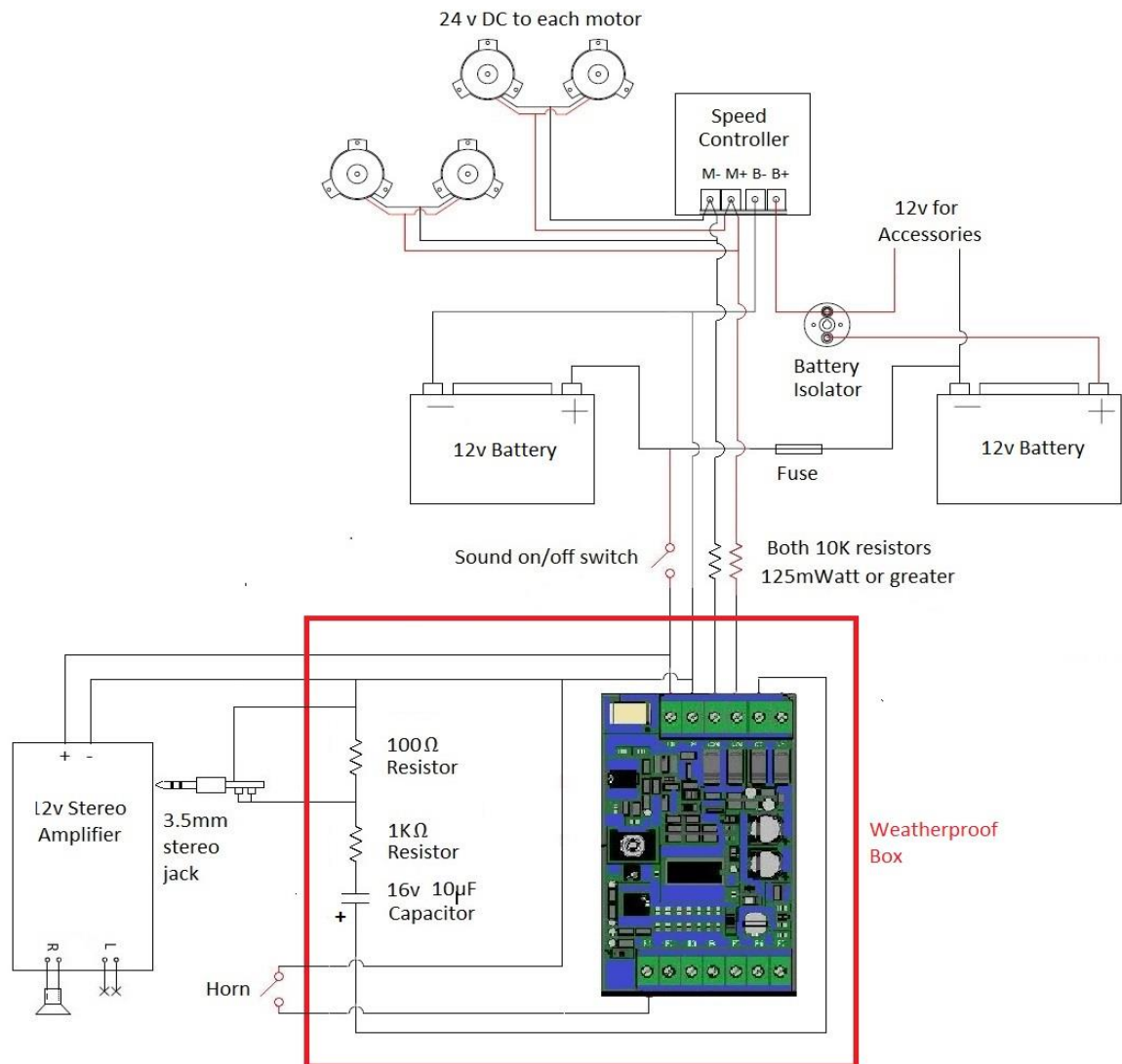

Classic US Universal Steam Instructions.doc Feb 8 2023

For more information, please visit the web site at [www.mylocosound.com](http://www.mylocosound.com) or e-mail [sales@mylocosound.com](mailto:sales@mylocosound.com).

Copyright © 2013-23 MyLocoSound Pty. Ltd.

TV Remote Control	Beeps	Mute Pressed - Sound Setting	Enter Pressed - Operating Setting
<b>Power Button</b>	1	Chuff maximum sensitivity to throttle changes	<b>Locomotive is battery powered</b>
	2	▼ ▼ ▼	Locomotive is track powered with 9v battery
	3	▼ ▼ ▼	Locomotive is track powered with 7.2v battery
	4	▼ ▼ ▼	
	5	Chuff minimum sensitivity to throttle changes	
<b>Button 0 - Country</b>	1		
<b>Button 1 - Whistle</b>	1	Hooter whistle	<b>Manual whistle control</b>
	2 & 3	3 chime whistles	Automatic Whistle every 20 secs
	4	5 chime whistle	US whistle rules with grade crossing
	5	<b>6 chime whistle</b>	
<b>Button 2 - Bell</b>	1	Brass bell	Manual on/off
	2	<b>Bronze bell</b>	Automatic timed ring when F2 is triggered.
	3	Manual short whistle	<b>Rings when motor below 4 volts</b>
	4		Rings when motor below 8 volts
	5		Rings when motor below 12 volts
	6		Rings once each time button is pressed
<b>Button 3 - Guard</b>	1	<b>"All aboard"</b>	<b>Manual</b>
<b>Button 4 - Safety Valve</b>	1		Manual on/off
	2		Throttle nudge operated
	3		<b>Automatic once a minute</b>
	4		Automatic once every three minutes
<b>Button 5 - Brake Pump</b>	1	<b>Slow pump</b>	Manual on/off
	2		Automatic each time the locomotive stops
	3		<b>Automatic for 20 secs per minute</b>
<b>Button 7 - Chuff</b>	1	<b>Deeper, big engine chuff</b>	<b>Voltage triggered 2/4 Cylinder (4 chuffs/rev.)</b>
	2	Sharper, small engine chuff	Voltage triggered 3 Cylinder (6 chuffs/rev.)
	3		Switch/Wheel trigger at F7 terminal and motor Switch/Wheel trigger and no motor
<b>Button 8 - Decelerating</b>	1	<b>Brake squeal</b>	<b>Not used</b>
	2	Rod clank when slowing to a stop	Automatic with clank at 6 to 12 motor volts
	3	Both rod clank and brake squeal	Automatic with clank at 4 to 8 motor volts
	4		Automatic with clank at 3 to 6 motor volts
<b>Button 9 - Drain Cocks</b>	1		<b>Not used</b>
	2		Automatic after a one minute stop
	3		Automatic after a three minute stop

Default settings are shown in bold.